

CLIPPER OFFICE TESTER & CLEANER

The Clipper Model 400 Office Tester & Cleaner offered by Seedburo is an extremely efficient cleaner for office and laboratory use. This machine will provide accurate, dependable performance for small lot cleaning, testing or sampling. It is commonly used in seed plants for sampling large lots of seed for correct screen selection on larger, commercial size cleaners. It is also widely used in university laboratories for agronomy research and testing. Flower and vegetable growers use the Model 400 for specialized cleaning, grading and sizing. The Model 400 has a compact, portable design and features an eccentric (shoe) drive that uses two (2) 10" x 15" screens. One top screen for scalping, one bottom screen for cleaning and grading. Perforated metal or wire cloth screens are available in over 175 different sizes (For screen perforations, see pg. 78). Other features include a powerful bottom blast fan driven by a three-step pulley, adjustable slide on the air intake openings to provide intermediate air regulation and an optional, removable catchall with either removable trays (shown) or solid bottom to catch air screenings. Net wt. 70 lbs. Actual dims 25" L (45 3/4" L with catchall) x 17" W x 23" H. Domestic ship wt. 110 lbs. Domestic ship dims. 32" L x 24" W x 32" H. Export ship wt. 185 lbs. Export ship dims 33" L x 25" W x 33" H.



Shown with optional Back Air Catchall with removable trays



Office Tester and Cleaner complete with 2 screens - 1/6 HP, 115V, 60Hz/1PH	No. 400/B
Office Tester and Cleaner complete with 2 screens - 1/6 HP, 230V, 60Hz/1PH	No. 400/E
Office Tester and Cleaner complete with 2 screens - 1/4 HP, 230V, 50Hz/1PH	No. 400/C
Office Tester and Cleaner complete with 2 screens - 1/4 HP, 230V, 50Hz/1PH Motor, CE Certified.....	No. 400/CE
Back Air Catchall with solid bottom (Optional).....	No. 400BAC
Back Air Catchall with removable trays (Optional).....	No. 400BACT
Extra Perforated Metal Screens	No. 400SM
Extra Wire Mesh Screens.....	No. 400SW
Required Domestic Packing	No. 400/DOM
Required Export Crating	No. 400/EX

CLIPPER MODEL AGM224 SEED & GRAIN CLEANER

The Clipper AGM224 cleaner is a mid-range cleaner that will provides excellent results and fits the market for those in need of a cleaner larger than the Office Clipper and smaller than the Eclipse 324 cleaner. This unit is ideal for small production, in lab, or on-farm applications. The AGM224 is a durable cleaner and features a steel frame, galvanized steel shoe, scotch-ply hangers, heavy-duty eccentric (shoe) drive, ball tray cleaning system and plain inlet hopper. Designed with two (2) 24-1/2" x 22-1/4" screens. The top screen handles scalping while the bottom screen offers thorough cleaning and grading. An adjustable air separation efficiently completes the cleaning process. With over 175 different screen sizes (perforated metal and wire mesh) available the AGM224 is an extremely versatile machine. Actual wt. 575 lbs. Actual dims 54"L x 41"W x 67"H. Ship wt. 895 lbs. Ship dims 56"L x 45"W x 70"H. (For screen perforations, see pg. 78).

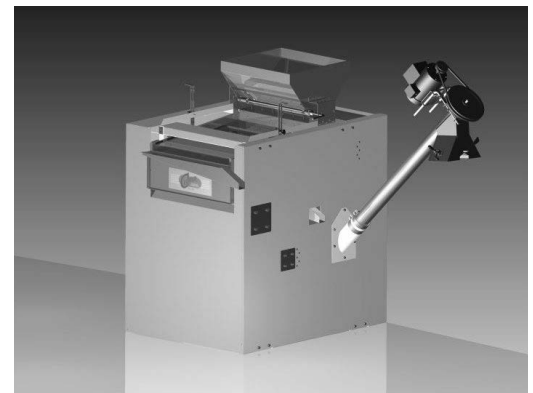

Shown with optional Bagging Auger



Clipper AGM224 Cleaner complete with 2 Screens, 1 HP, 110/220V, 60 Hz, Single Phase	No. AGM224
Clipper AGM224 Cleaner complete with 2 Screens, 1 HP, 110/220V, 50 Hz, Single Phase	No. AGM224/A
Extra Standard Metal Perforated Screens.....	No. AGM224SM
Extra Standard Metal Perforated Screens, Cross Slots	No. AGM224SMCS
Extra Square Wire Mesh Screens	No. AGM224SWS
Extra Rectangle Wire Mesh Screens.....	No. AGM224SWR
Bagging Auger Attachment.....	No. AGM224BA
Required Domestic Crating	No. AGM224/DOM
Required Export Crating	No. AGM224/EX